

RESEARCH MBD-SYSTEM RS-3

*Modular, expandable
Ready-for-use*

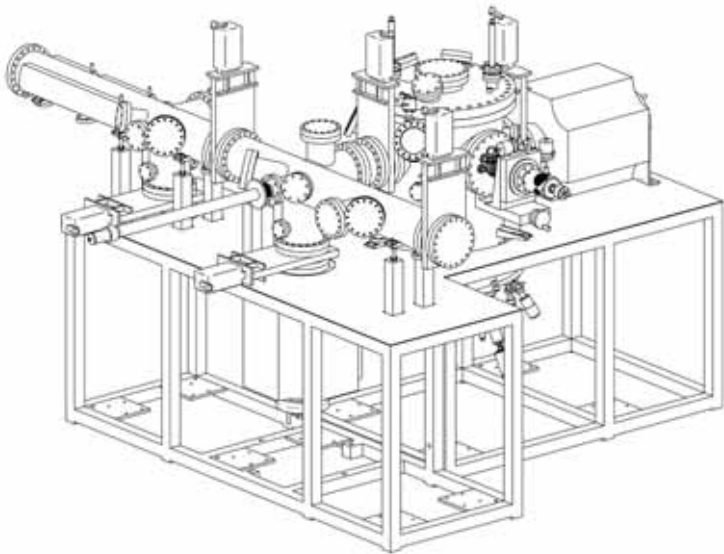

Complete MBD System for the preparation of epitaxial films (semiconductors, metals, dielectrics and organics) on 2" (optional 3") wafers for various scientific applications.

- UHV-compatible (achievable base pressure better than 5×10^{-11} mbar in the growth chamber)
- High precision and high quality standard (Made in Germany)
- Easy-to-handle
- State-of-the-art technology (substrate temperature and film thickness uniformities better than +/- 1%)
- Ready for use after installation on site

Description of the RS-3

The system is based on three chambers: a growth chamber, a combined buffer and preparation chamber and a load-lock chamber with the possibility to mount additional chambers (like surface analysis chambers, further growth chambers or processing chambers).

Growth chamber

- 18" chamber made from stainless steel
- With up to 10 cell ports
- Equipped with 5 effusion cells including shutters dependent on the material system which will be prepared
- Equipped with a manipulator for 2" or 3" wafer holders heatable up to 800°C with endless rotation
- A cooling shroud in the area of the substrate
- A high efficient cooling shroud in the area of the effusion cells, with overlap to the first cooling shroud, specially designed
- Ion getter pump with booster

Buffer and preparation chamber

- With sample heater for temperatures up to 600°C
- With the option to mount plasma cells and/or a gas inlet facilities for sample treatment
- Ion getter pump with booster

Load-lock chamber

- Sample transfer
- Loading door
- Turbo molecular pump with roughing pump

Miscellaneous

- With cabinet including all needed controllers
- Complete bake-out system
- Mounted on a stable rack
- Expandable with further UHV-equipment (e.g. analysis chambers for STM, AFM, UPS, XPS, KERR, LEED, etc.)

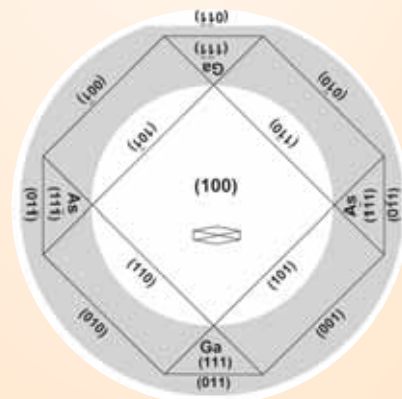

Surface orientation of GaAs(100)-wafer



CREATEC FISCHER & CO. GMBH

Industriestraße 9
D-74391 Erligheim
Germany

General Manager: Albrecht Fischer

Tel.: +49 7143 96 70 - 0

Fax: +49 7143 96 70 - 27

E-mail: sales@createc.de

Internet: www.createc.de